







# LOW PROFILE LP RANGE

## LP-F8 & LP-SM8A INSTALLATION GUIDE

### LP-F8 & LP-SM8A Self tapping female and surface mount male

<b>LP-F8</b> 	<b>USE WITH:</b> LP-SM8AS 	<b>INSTALL WITH:</b> 1Ø drill      CT-19  
---	---	--

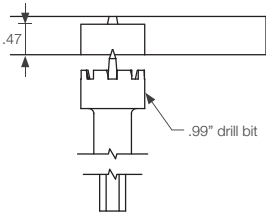
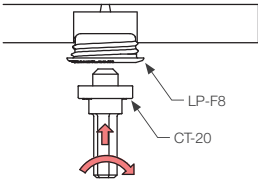
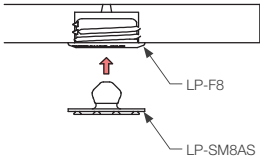
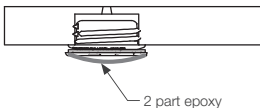
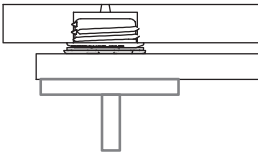
### INSTALLATION STEPS Using LP-SM8AS - adhesive fix option

<p><b>1</b> Drill .99"Ø hole in frame</p> 	<p><b>2</b> Screw LP-F8 into frame. use battery drill with clutch set.</p> 	<p><b>3</b> Fit LP-SM8AS into LP-F8</p> 
<p><b>4</b> Adhesive to LP-SM8AS</p> 	<p><b>5</b> Drill panel on mark with CT-09</p>  <p>Place panel in position, and support while adhesive dries</p>	<p>Install Note: CT-12 to CSK hole edge in hard material (0.04"-0.08")</p> <p>For more solid substrates such as fiberglass, use a 1 1/16" x 1/8" tap to pre-thread the hole before installing the LP-F8</p> 

**A** Cutaway view of installed clip (panel removed)

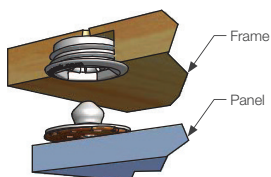

MORE INFO: Clip Layout guide TD-02 & TD-08